



**ECLIPSE  
MAGNETICS**

# CATALOGUE



-  Permanent Magnets
-  Magnetic Workholding
-  Magnetic Tools
-  Magnetic Assemblies
-  Merchandiser Range
-  Separation

**Distribution Products**

BSEN ISO 9001 : 2000



Certificate No. FM31278

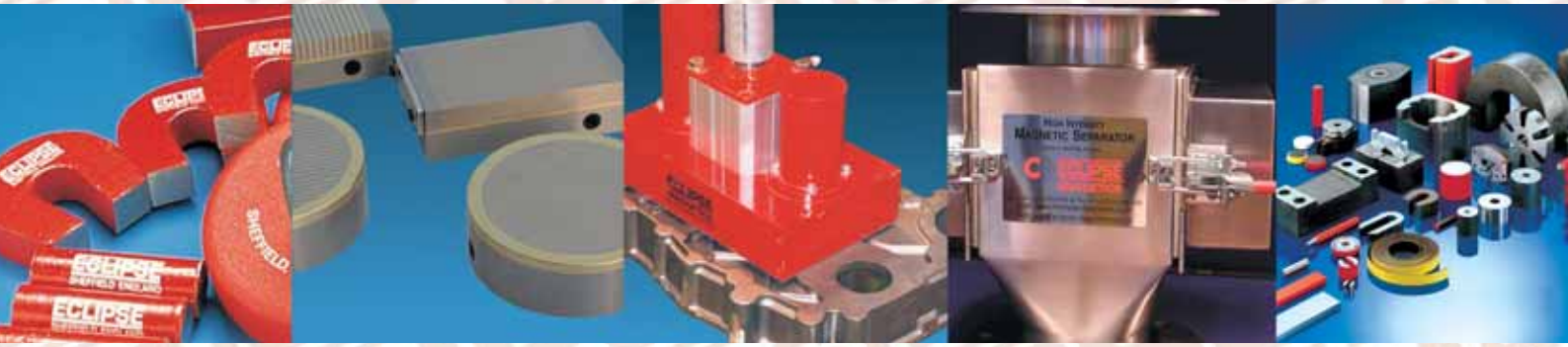

## Eclipse Magnetics moving towards a new future...

The world is ever changing and each day new demands are made on industries of all sectors. Eclipse Magnetics is determined to keep pace with this new world and supply products and solutions that will help you in overcoming these new challenges.

From our UK base we are providing services on a global platform.

### Our aim is to provide...

- A customer facing company that will provide products and solutions through a **global distribution network**
- A globally recognised brand - the leading name in **Magnetics**
- Competitive pricing - **the right product at the right price**
- Proactive technical support - **added value** to our customers

Eclipse Magnetics Limited have been at the forefront of magnetic product design and manufacture for over 80 years. Eclipse Magnetics is part of the Spear and Jackson Group of Companies. The Eclipse brand is internationally renowned for high levels of quality and performance. The company's dedication to this standard is reflected in the accreditation of the internationally recognised ISO quality award. Eclipse Magnetics manufacture and supply a comprehensive product range of the following :



## Permanent Magnets

Pages 01 - 03

- Cylindrical & Rectangular Bar Magnets
- Button Magnets, Minor & Major Magnets
- Pocket, Power & Deep Pot Magnets
- Shallow Pot & Neo-Hold Bi-Pole Magnets
- Magnetic Foot & Ferrite Channel Magnet
- Ferrite Shallow, Heavy Duty Ferrite Shallow Pot Magnets
- Magnet Discs, Marker Magnets & Flexible Magnets



## Magnetic Tools

Pages 08 - 11

- Complete Magnetic Stands, Bases & Fitment Sets
- Variable Clamps
- Magnetic 90° Fixed & Adjustable Link Clamps
- Magnetic Quick, Mitre & Earth Welding Clamps
- Hand Magnet, Magnetic Holder & Magnetic Holdfasts
- Magnetic Positioner, Plate Drag & Recovery Magnet
- Magnetic Vice Jaws, Sheet Floaters & Tool Rack
- Telescopic Pick-up Magnet & Tool Mat



## Magnetic Workholding

Pages 04 - 07

- **Premier Range** Rectangular, Circular & Radial Pole Magnetic Chucks
- **Standard Range** Rectangular, & Circular Magnetic Chucks
- Vee Blocks, Magnetic Vices & Chuck Blocks
- Tunnel & Table Top Demagnetizers
- **Ultralift Plus™** Magnetic Lifter



## Magnetic Assemblies

Page 12

- Magnetic Hooks
- Samarium Cobalt Deep Pot Magnet
- Alnico Deep Pot Magnet
- Samarium Cobalt ShallowPot Magnet
- Ferrite Pot Magnet - Thread Hold
- Ferrite Pot Magnet - Fixed Hole



## Merchandiser Range

Pages 13 - 14

- Merchandiser Display Stands
- Product Pack A & B
- Product Pack C, D & F



## Separation

Page 15

- Magnetic Rods & Magnetic Sampling Probe
- Magnetic Strips & Magnetic Grids-Square
- Easy Clean Magnetic Grids-Square & Magnetic Grids-Circular

*Whatever your magnetic needs, Eclipse Magnetics have the expertise and experience to propose an effective solution.*

## Cylindrical Bar Magnets

- Material: Alcomax III
- Can be used in temperatures up to 550°C

Product No.	Diameter	Length	Weight per pair (kg)	Units (per pack) (pairs)
E805	6	20	0.02	10
E806	8	25	0.04	5
E807	10	30	0.07	5

All dimensions are in millimetres  
Supplied in pairs



## Rectangular Bar Magnets

- Material: E844, E845, E846 Alcomax III, E842, E843 Alnico
- Can be used in temperatures up to 550°C
- North pole is indicated by a notch

Product No.	Width	Height	Length	Weight per pair (kg)	Units (per pack) (pairs)
Material: Alcomax III					
E844	10	5	20	0.03	5
E845	12.5	5	40	0.04	5
E846	15	5	60	0.13	5
Material: Alnico					
E842	15	10	50	0.22	1
E843	15	10	75	0.33	1

All dimensions are in millimetres  
Supplied in pairs



## Button Magnets

- Material: Alnico
- Can be used in temperatures up to 550°C

Product No.	Diameter	Height	Slot Size (Min-Max)	Hole size	Weight (kg)	Max pull (kg)	Units (per pack)
E821	12.5	9.5	4.0 - 7.2	4.5	0.006	0.7	10
E822	19.1	12.7	5.6 - 8.7	4.8	0.02	1.9	10
E823	25.4	15.9	5.6 - 8.7	4.8	0.05	3.4	10
E824	31.8	25.4	8.0 - 12.7	7.1	0.113	4.8	5
E825	22.2	19.1	6.4 - 6.4	4.8	0.05	3	10

All dimensions are in millimetres



## Minor Magnets

- Material: Alnico
- Can be used in temperatures up to 550°C

Product No.	Depth	Height	Width	Weight (kg)	Pole gap	Max Pull (kg)	Units (per pack)
E801	7.9	11.1	22.2	0.02	6.4	0.9	10

All dimensions are in millimetres



## Major Magnet

- Material: Alcomax III and mild steel
- The large gap design provides the highest practical field strength

Product No.	Height (mm)	Width (mm)	Depth (mm)	Weight (kg)	Pole area (mm)	Pole gap (mm)	Flux density at gap centre (Wb/m <sup>2</sup> )	Gauss	Units (per pack)
862	111	103.5	50	2.9	22.2 x 52.4	27.3	0.210	2000	1

All dimensions are in millimetres



## Pocket Magnets

- Material: Alnico
- Can be used in temperatures up to 550°C

Product No.	Length	Height	Width	Width of gap	Weight	Max Pull (kg)	Units (per pack)
E802	22.2	25.4	7.9	6.4	0.03	2.4	10
E803	27	35	15.9	7.9	0.09	4	5

All dimensions are in millimetres



## Power Magnets

- Material: Alcomax
- Can be used in temperatures up to 550°C

Product No.	Length	Height	Width	Width of gap	Hole size	Weight (kg)	Max pull (kg)	Units (per pack)
811	30	20	20	15	5	0.06	4.5	5
812	40	25	25	20	5	0.12	9	5
813	45	30	30	23	5	0.18	11.8	1
814	58	35	40.5	27.8	2 x 7.9	0.37	23.5	1
815	70	41.3	57.2	34.1	2 x 7.9	0.71	37	1
816	79.4	54	82.6	38.5	2 x 9.5	1.45	47	1
817	60.3	40	62	31.75	n/a	0.8	35	1
818	79.4	54	85.7	47.6	n/a	1.8	60	1

All dimensions are in millimetres



## Deep Pot Magnets

- Material: Alcomax III (magnet), mild steel (body), aluminium (spacer)
- Can be used in temperatures up to 220°C

Product No.	Diameter	Height	Thread size	Weight (kg)	Max pull (kg)	Units (per pack)
829	9.5	15.1	M3	0.005	1	10
830	12.7	15.9	M4	0.015	2	10
831	17.5	16	M6	0.023	2.65	10
832	20.5	19	M6	0.040	4	5
833	27	25	M6	0.085	6.1	5
834	35	30	M6	0.184	14.75	1

831, 832, 833, 834 - available with 10 UNF or 1/4 UNC thread on a made to order basis

All dimensions are in millimetres



## Shallow Pot Magnets

- Material: Alcomax III (magnet), mild steel (body)
- Can be used in temperatures up to 550°C (except 826: 100°C)

Product No.	Diameter	Height	Hole size	Screw head size	Weight (kg)	Max pull (kg)	Units (per pack)
826	19.1	7.5	3.7 - 6.7	M3 Csk	0.01	3	10
827	28.6	8.7	4.8 - 8.6	M4 Csk	0.03	5	10
828	38.1	10.35	4.8 - 8.6	M4 Csk	0.08	13	5

All dimensions are in millimetres



## Neo-Hold Bi-Pole Magnets

- Material: Neodymium Iron Boron (magnet), aluminium (body)
- Can be used in temperatures up to 100°C

Product No.	Diameter	Height	Weight (kg)	Thread size	Max pull (kg)	Units (per pack)
NH 025	12.7	11.6	0.01	M5	2	10
NH 065	16	15.6	0.018	M6	5	10
NH 130	22	20	0.04	M6	9	5
NH 240	25	25	0.07	M6	15	5

All dimensions are in millimetres



## Magnetic Foot

- Material: Alcomax III (magnet), mild steel (pot)
- Rectangular block containing two pot type magnets set into one mild steel housing
- Can be used in temperatures up to 220°C

Product No.	Diameter	Height	Width	Weight (kg)	Thread size	Max pull (kg)	Units (per pack)
920 SUOT	60	25	25	0.32	M6	12	1

All dimensions are in millimetres



## Ferrite Channel Magnet

- Can be used in temperatures up to 80°C
- Shallow limpet type magnets set in a mild steel shell

Product No.	Length	Width	Height	Weight each (kg)	Plain fixing holes	Max pull (kg)	Units (per pack)
E898/2	130	30	13	0.25	4.2	14	5
E899	190	43	13	0.50	4.2	48	2

All dimensions are in millimetres



## Ferrite Shallow Pot Magnets

- Can be used in temperatures up to 80°C
- Especially suitable for bases for machine tool accessories

Product No.	Diameter	Height	Weight (kg)	Max pull (kg)	Thread Size	Units (per pack)
E890	46	10.7	0.09	6	M6	5
E891	56	10.7	0.13	16	M6	5
E892	66	10.7	0.19	25	M6	5

All dimensions are in millimetres  
Supplied with removable hook



## Heavy Duty Ferrite Shallow Pot Magnets

- Can be used in temperatures up to 80°C
- Especially suitable for bases for machine tool accessories
- Three M6 tapped holes with removable jacking screw

Product No.	Diameter	Height	Weight (kg)	Central fixing point	Fixing stud centres PCD	Max pull (kg)	Units (per pack)
E895	66	10.7	0.27	M6	46mm/3 holes	25	1
E896	76	12.5	0.30	M6	46mm/3 holes	33	1
E897	100	15	0.61	M6	70mm/3 holes	55	1
E896/2*	76	12.5	0.30	22mm	46mm/3 holes	33	1
E897/2*	100	15	0.61	22mm	70mm/3holes	55	1

\* Supplied without hooks, the three additional holes are clearance holes  
All dimensions are in millimetres



## Magnetic Discs

- Material: Ferrite magnet
- Can be used in temperatures up to 80°C
- Highly resistant to demagnetisation

Product No	Diameter	Thickness	Units (per pack)
CM 700-R	14	5	10
CM 701-R	20	5	10
CM 702-R	30	5	10

The magnets have a variety of uses including: holding notes, drawings, plans etc. on steel surfaces

All dimensions are in millimetres



## Marker Magnets

- Available in bulk supply, minimum of 100 off
- Available in white, black, red, blue, yellow and green and in 15, 20, 30 and 40mm diameters

The magnets have a variety of uses, including:  
- holding notes, drawings, plans etc, on steel surfaces



## Flexible Magnets

- Material: Strontium Ferrite
- Supplied in sheet, strip and adhesive backed finishes
- Flexible strip and sheets available with a coloured vinyl finish
- Can be cut with scissors
- Can be used in temperatures up to 80°C

### Plain, Flexible Magnetic Strip

Product No.	Width	Thickness	Length (metres)	Units (per pack)
FM 670	9.5	3.6	10	1
FM 671	11	4.6	10	1
FM 672	15	6.4	10	1
EM 880-R	9.5	3.6	2	1

### Adhesive Backed Flexible Magnets

Product No.	Width	Thickness	Length (metres)	Units (per pack)
FM 660	7.5	0.75	10	1
FM 661	12.5	0.75	10	1
FM 662	20	0.75	10	1
EM 884-R	13	0.5	1	1
EM 888-R (pairs)	9.5	3.6	150 mm	10 pairs
FM 650	150 sq.	0.75	150 mm sq.	5

All dimensions are in millimetres

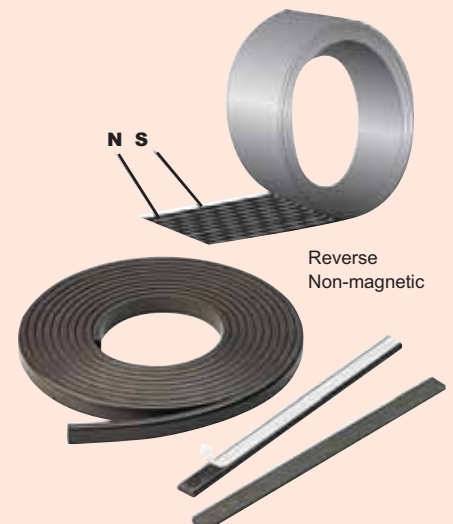

## Premier Range Magnetic Chucks

Based on the first Permanent Magnet Chuck invented in 1934 by Eclipse Magnetics the current Premier Range has evolved to embody the design and quality that typifies the standard of excellence in the market place, a true Eclipse champion.

- The all-metal top plate is extra thick to ensure maximum accuracy after frequent re-grinding
- Chrome plated side and end stops for packing and positioning
- A 3-year guarantee against faulty workmanship and materials
- The chucks can be partially magnetised to allow part positioning in set up
- Removable, ergonomically designed handles allow easy switching

## Rectangular Magnetic Chucks

Product No.	A	B	C	D	E	F	Pole pitch
AX510/P	258	276	19	14	53	129	35
AXS612/P	310	322	19	19	65	151	32
AXS614/P	351	360	19	19	65	151	32
AXS618/P	451	451	19	19	65	151	32
AXM820/P	501	501	19	19	66	201	35
AXM824/P	601	601	19	19	66	201	35
AXM1020/P	501	501	22	19	69	251	35
AX47/P	178	203	10	9	40	127	35
AX255/P	134	N/A	12	N/A	75	64	35

Supplied with clamps  
All dimensions are in millimetres

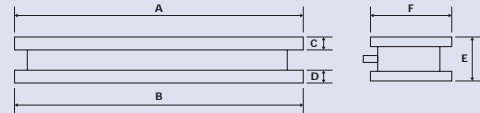
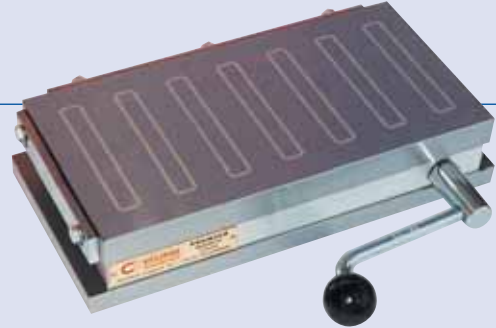

## Circular Chuck

The unique top plate configuration means that the magnetic energy is concentrated on to the top face of the chuck.

- The chucks can be partially magnetised to aid the correct positioning of the workpiece
- Grooved rings in the top plate assist in visual positioning to aid quick changeover in set up
- Excellent for holding thin ring shaped components that can be subject to radial distortion
- Removable, ergonomically designed handles allow easy switching

Product No.	A	B	C	D	H	I	K
AX475C/P	121	45	51	6	76	M6	102
AX651C/P	165	57	76	4	102	M10	140
AX91C/P	229	60	86	5	114	M10	191
AX12C/P	305	76	152	5	184	M12	254
AX15C/P	381	83	197	8	N/A	M12	235

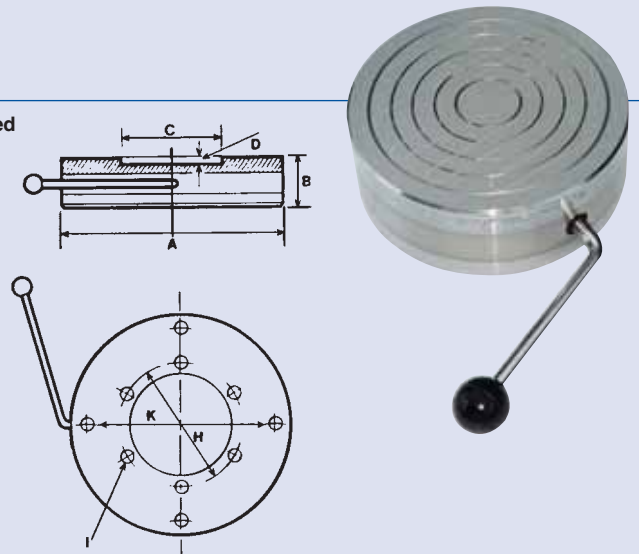

## Radial Pole Magnetic Chuck

The radial pole configuration concentrates the entire magnetism of the chuck into the workpiece – ideal for a wide range of operations from precision grinding to heavy turning.

- Dynamically balanced to enable use at high rpm
- All metal top plate and a rugged, industrial build ensures accuracy and longevity
- Through – bore (except the NR100C) allows through flushing of coolant during machining

Product No.	A	B	C	D	H	I	L	M	No. of Poles
NR100C	100	48	51	6	N/A	M6	76	N/A	6
NR150C	150	69	76	4	N/A	M10	102	36	10
NR225C	225	71	86	5	114	M10	191	54	14
NR300C	300	71	152	5	184	M12	254	66	18
NR350C	350	83	197	8	N/A	M12	235	66	18

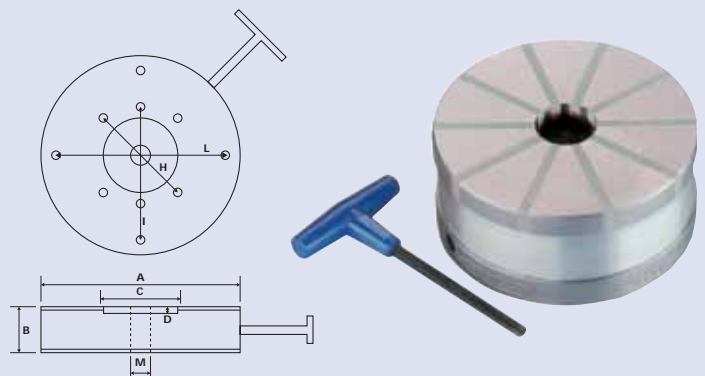

## Standard Range Magnetic Chucks

Standard Range Chucks are designed to give high performance combined with competitive pricing. Using high energy Rare Earth Permanent magnets they give an evenly distributed clamping force. Trouble free operation is assured with a rugged but accurate build.

- Brass and steel top plates
- Removable hexagon key handles ensure ease of operation through a 180-degree arc and replacement handles can be easily sourced if misplaced
- All chucks are supplied with Side and End stops
- All chucks are supplied with clamps

## Rectangular Magnetic Chucks

### Standard Pole

Pole spacing = 4.0mm Steel / 2mm Brass

Force = 80N/cm<sup>2</sup>

#### Clamps included

- These chucks are primarily designed for grinding operations
- Will effectively clamp all workpiece thicknesses down to 3mm
- Used for all general grinding applications

Product No.	W(mm)	L(mm)	Ht.(mm)	Wt. (kgs)
ERSP1018	100	180	50	8
ERSP1325	130	250	50	14
ERSP1530	150	300	50	18.5
ERSP1535	150	350	50	21.5
ERSP1545	150	450	50	27.5
ERSP2060	200	600	50	50

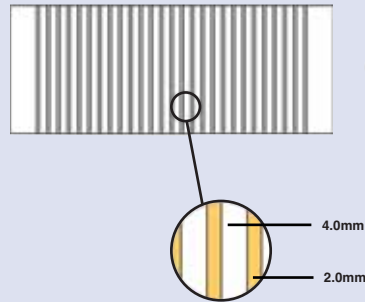
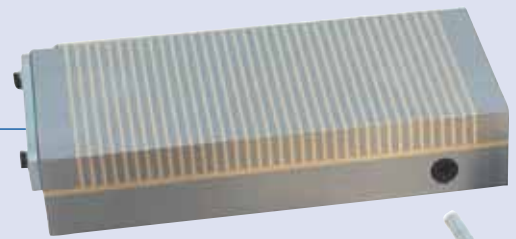

## Rectangular Magnetic Chucks

### Fine Pole

Pole spacing = 1.5mm Steel / 0.5mm Brass

Force = 80N/cm<sup>2</sup>

#### Clamps included

- These chucks are ideally suited for small or thin workpieces  
This usually means thicknesses less than 3mm

Product No.	W(mm)	L(mm)	Ht.(mm)	Wt. (kgs)
ERFP1018	100	180	50	8
ERFP1325	130	250	50	14
ERFP1530	150	300	50	18.5
ERFP1535	150	350	50	21.5
ERFP1545	150	450	50	27.5
ERFP2060	200	600	50	50

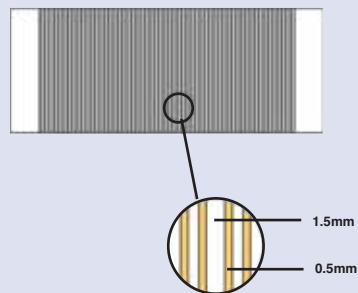
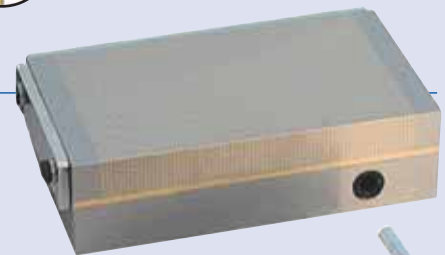

## Circular Magnetic Chucks

**Standard Pole** Pole spacing = 4.0mm Steel / 2mm Brass  
Force = 80N/cm<sup>2</sup>

Product No.	Dia. (mm)	Ht.(mm)	Wt. (kgs)
ECSP100	100	50	3
ECSP125	125	50	5
ECSP160	160	50	7.5
ECSP195	195	50	11
ECSP255	255	50	16
ECSP310	310	50	24
ECSP350	350	50	27

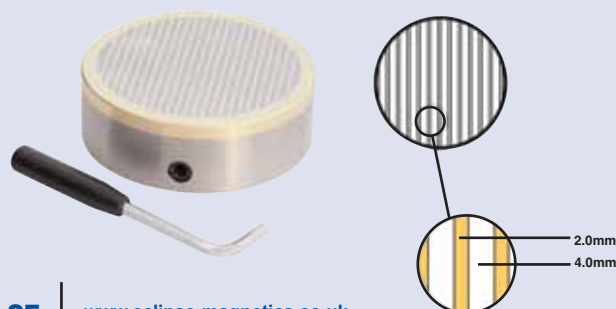

**Fine Pole** Pole spacing = 1.5mm Steel / 0.5mm Brass  
Force = 80N/cm<sup>2</sup>

Product No.	Dia. (mm)	Ht.(mm)	Wt. (kgs)
ECFP100	100	50	3
ECFP125	125	50	5
ECFP160	160	50	7.5
ECFP195	195	50	11
ECFP255	255	50	16
ECFP310	310	50	24
ECFP350	350	50	27

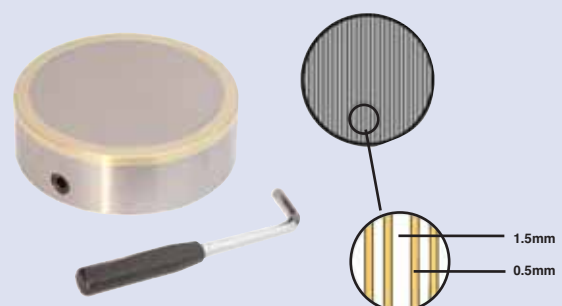

## Magnetic Vee Blocks

- Contains Alcomax III magnetic materials
- The units are suitable for holding cylindrical and complex workpieces for marking, spark erosion, grinding and measurement operations.

Product No.	Width (mm)	Length (mm)	Height (mm)	Weight (mm)	Max Clamping Forces	
					Top (kg)	Bottom (kg)
E934-single unit	69.85	101.6	95.25	3.96	200	150
E934 MP	69.85	101.60	95.25	7.92	200	150
E935-single unit	69.85	80	95.25	3.12	160	120
E935 MP	69.85	80	95.25	6.24	160	120

All dimensions are in millimetres  
MP = Matched Pair



## Magnetic Vice

- This high quality vice is ideally suited for use in machining applications where accuracy and holding of irregular workpieces are required (V face of the jaw can be aligned to the workpiece face)

Product No.	Width	Length	Height	Weight (kg)	Hardened
E927	108	170	68.3	7.65	55 Rc min

All dimensions are in millimetres



## Chuck Blocks

- Supplied in matched & numbered pairs
- They may be used horizontally or vertically
- Can be machined to accommodate awkward workpieces
- Can be used to extend the flux paths of a magnetic chuck with parallel poles

Product No.	Width	Length	Height	Weight (kg)	Units per pack
950	75	60	30	1.45	1 matched pair
950V	100	50	40	1.70	1 matched pair

All dimensions are in millimetres

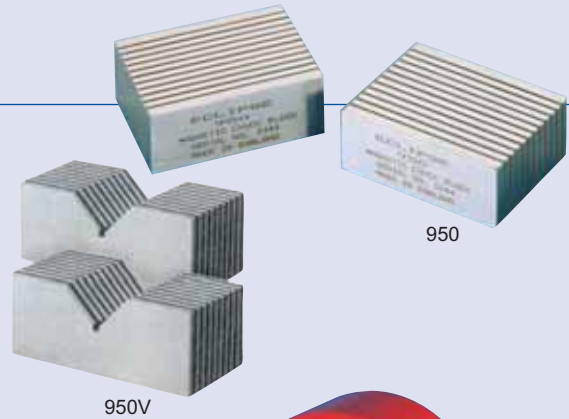

## Tunnel Demagnetiser

- Highly durable bench mounted unit used for the removal of residual magnetism from components after magnetic workholding
- Capable of demagnetising small or large hand tools up to 69mm diameter

Product No.	Width	Height	Depth	Weight (kg)
TDM240	130	190	78	3.25

All dimensions are in millimetres



## Table Top Demagnetiser

- Lightweight units for the removal of residual magnetism from components after workholding
- CE approved

Product No.	Voltage	Width	Height	Depth	Weight (kg)
DA 955/uk	240	150	117	87	3.83
DB 956	110	150	117	87	3.83
DB 956 can	110	150	117	87	3.83
DB 956/eur	110	150	117	87	3.83

All dimensions are in millimetres



## Ultralift<sup>plus</sup>+

Magnetic Lifters are quicker and easier to use than slings, chain or mechanical grabs and do not mark the finish of the load.

The **Ultralift Plus™** still incorporates the (Patented) 'Safety Shim'. The New Unique Lifting Eye Mechanism (Patent Pending) that isolates the operating handle while a load is suspended by the **Ultralift Plus™** means that *'safe just got safer'*

### How easy is it to use?

The **Ultralift Plus™** is so simple to use, it functions under the same principles as the **Ultralift™**. Once the 'Safety Shim' test has been completed you simply lower the **Ultralift Plus™** onto the work piece, then by depressing the button on the safety handle (like a car handbrake) the handle can be turned through 120° until it locks under the safety catch - the component can now be lifted. At this stage the Lifting Eye is under tension, activating the operating handle isolator, guaranteeing the load cannot be dropped by accidental switching.



Model No.	Weight (kg)	Dimensions (mm)						Flat Section		Round Section		
		A	B	C	D	E	F	SWL (kg)	Thickness Min (mm)	Length Max (mm)	SWL (kg)	Diameter Max (mm)
<b>UL0125+</b>	4	101	155	69	74	64	152	125	20	1500	50	200
<b>UL0250+</b>	11	155	214	92	96	94	218	250	25	1500	100	300
<b>UL0500+</b>	27	224	300	122	128	123	266	500	30	1500	200	400
<b>UL1000+</b>	63	260	359	176	174	140	391	1000	45	1500	400	450
<b>UL2000+</b>	157	368	477	233	227	195	493	2000	55	2000	800	600

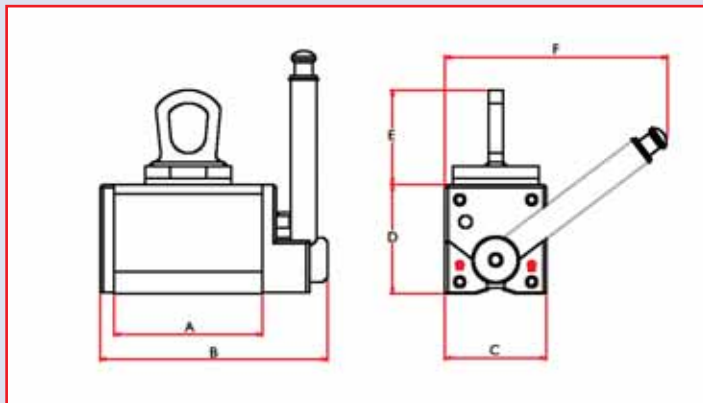

## Magnetic Chuck and Lifter Repair Service



We REPAIR and TEST ALL MODELS of Permanent Magnetic CHUCKS, LIFTERS and MAGNETIC TOOLS

- Free Inspection & Quotation
- 1 Year Warranty on all Eclipse Magnetics chucks
- 1 Year Warranty on all other manufacturers chucks
- Certificate of performance for magnetic lifters

All magnetic chucks are surface ground and given the Eclipse clean-up treatment

**Call our Repair Line on: +44 (0)114 225 0618**

# Magnetic Tools

Dials not included



## Complete Magnetic Stands

Product No.	Max pull (kg)	Base part no.	Switching type	Fitment part no.	Fitment type
E901	80	E901WF	Push button	RP991BL	Heavy duty with fine adjustment
E903CP	30	E900WF	Push button	RP72CP	Light duty
E908M	30	E900WF	Push button	RP995BL	Heavy duty
E905	80	E905WF	Lever	RP995BL	Heavy duty
E906	80	E905WF	Lever	RP991BL	Heavy duty with fine adjustment
E907M	80	E905WF	Lever	RP907S	Flexible snake arm
E910	80	E905WF	Lever	RP999	Mechanical one piece
E909	14	834	Non-switchable	RP909FIT	One pillar

- For use in the measurement, inspection and positioning of workpieces with dial indicators.
- To measure the flatness of a workpiece after grinding or milling.
- For checking concentricity of a workpiece.

All stands will clamp onto curved and flat surfaces (with the exception of E909)

## Magnetic Bases - Push button

- Have 4 magnetic faces
- Eclipse magnetic bases can be readily located on any ferrous surface to provide a rigid support

Product No.	Length (mm)	Width (mm)	Height (mm)	Weight (kg)	Hole sizes	Clamping force (kg)
E900WF	48	40	50	0.5	M8	30
E901WF	64	64	76	1.70	M8	80

All stands will clamp onto curved and flat surfaces (with the exception of E909)

All dimensions are in millimetres



## Magnetic Base - Toggle switch

Product No.	Length (mm)	Height (mm)	Width (mm)	Weight (kg)	Hole sizes	Clamping Force (kg)
E905WF	65	55	50	1.05	M8	80
E905WF/100	75	55	50	1.20	M8	100

All dimensions are in millimetres



## Fitment Sets for Magnetic Bases

Product No.	Pillar height	Pillar diameter	Crossbar length	Crossbar diameter	Screw fixing
RP72CP	185	12.5	150	6.3	M8
RP991BL	175	12	165	10	M8
RP995BL	175	12	165	10	M8

All dimensions are in millimetres

Product No.	Max extension height	Screw fixing
RP907S	315	M8
RP999	295	M8
RP907/FS	360	M8

All dimensions are in millimetres

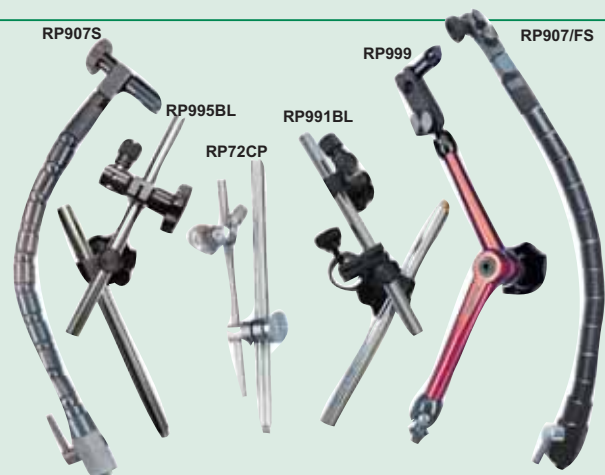

## Magnetic Variable Clamp

- Designed for fast accurate holding of ferrous sheets and tubes for welding and assembly work
- Maximum operating temperature up to 120°C



Product No.	Length (mm)	Height (mm)	Width (mm)	Weight (kg)	Pull (kg)
E952	195	200	11	0.49	20

NB Dimensions with arms set at 90°

## Heavy Duty Variable Clamp

- The Eclipse E974 provides the user with the means to clamp components during welding, fabrication and assembly applications with the added benefit of 40Kg clamping force, enabling larger components to be clamped with ease



Product No.	Length (mm)	Height (mm)	Width (mm)	Weight (kg)	Pull (kg)
E974	140	140	35	1.40	40

## Magnetic 90° Fixed Clamps

- Two magnetic faces in a rigid 90° angle for jiggling on sheets, pipes and tubes
- The Eclipse E971, E972 and E973 fixed 90° clamps provide a fast and cost effective means of clamping components rigid at 90° angles during fabrication, assembly and weld preparation applications

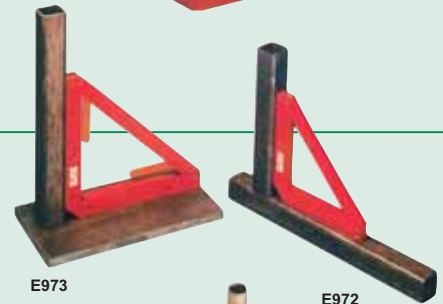

Product No.	Length (mm)	Height (mm)	Width (mm)	Weight (kg)	Pull (kg)
E971	140	140	35	1.40	40
E972	225	225	22	2.20	75
E973	300	300	35	4.70	200



## Magnetic Adjustable Links

- Clamping components at any angle for welding and assembly applications

Product No.	Length (mm)	Height (mm)	Width (mm)	Weight (kg)	Pull (kg)
920 SU - (single unit)	60	25	29	0.35	13
920 (pair)	127	25	51	0.70	13
920SUOT - (single unit original type)	60	25	29	0.32	12
920OTPR - (original type pair)	127	25	29	0.70	12

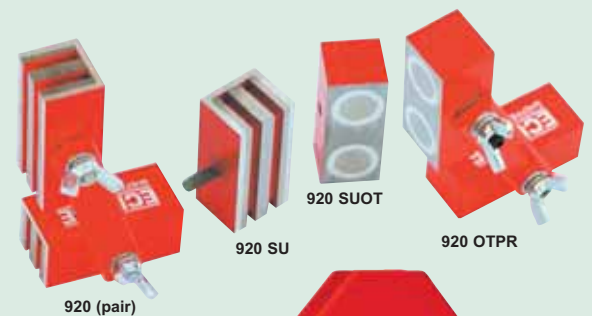

## Magnetic Quick Clamps

- The Eclipse Magnetic Quick clamps are designed to facilitate fast and accurate holding of ferrous metals
- Quick Clamps are also suitable for retrieval applications

Product No.	Length (mm)	Height (mm)	Width (mm)	Weight (kg)	Pull (kg)
E951	100.5	65	12	0.3	10
E953	100.5	65	21	0.4	15

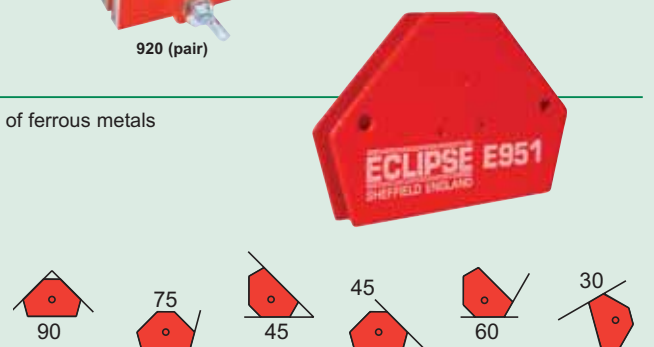

## Magnetic Mitre Clamps

- Effective and inexpensive method of clamping components
- The Eclipse 923 and 924 Mitre Clamps provide the welder with a simple means of clamping flat or round ferrous components

Product No.	Length base face (mm)	Length top face (mm)	Height (mm)	Width (mm)	Weight (kg)	Pull (kg)
923	152	70	44.5	41	1.36	100
924	178	95	44.5	41	1.64	68



# Magnetic Tools

## Earth Welding Clamp

All dimensions are in millimetres

- This magnetic clamp allows quick and easy earthing for most steel welding operations
- The Eclipse E945 Earth Welding clamp is designed to provide earthing on large welding operations where croc-clip or G-clamps cannot be easily used

Product No.	Width (mm)	Height (mm)	Thickness (mm)	Pull (kg)	Weight (kg)	Maximum Current (amps)
E945	82.5	130	36	50	1.4	350



## Hand Magnet

- This lightweight unit contains powerful ferrite magnets and is capable of attracting small ferrous components to the base of the tool
- The E961 is particularly useful for picking many small parts like nails or tacks that may have been spilt

Product No.	Length (mm)	Width (mm)	Height (mm)	Weight (kg)	Max pull (kg)
E961	121	41	235	2.75	1.15

All dimensions are in millimetres



## Magnetic Holder

- Contains powerful Alcomax magnetic material
- The E925 Magnetic Holder provides the welder with a powerful, rigid support on flat and round components at various angles during welding and welding preparation applications
- The E925 is switchable & can be partially energised

Product No.	Length (mm)	Height (mm)	Width (mm)	Weight (kg)	Max pull capacity (kg)
E925	108	140	108	5.67	100



## Magnetic Holdfasts

- The Magnetic holdfasts can be built into workholding, handling and assembly fixtures to provide a high clamping force and positive grip
- Maximum operating temperature is 100°C

Product No.	Diameter (mm)	Height (mm)	Fixing holes PCD	No. of holes	Weight (kg)	Max pull (kg)
E 939	44.5	44.5	31.8	2	0.6	20
E 940	55.0	49.5	38.1	2	1.0	40
E 941	70.0	63.5	50.8	2	2.0	88
E 942	100.0	74.5	69.1	3	4.7	183



Contains Alcomax 3 magnetic material  
Supplied with screw release handle

## Magnetic Positioner

- The 922 Magnetic Positioner is a heavy duty unit consisting of 2 magnetic blocks connected by 2 non magnetic steel straps
- The blocks contain high performance Alcomax 3 magnetic material
- Magnetic on two faces
- On/Off switch located at each end

Product No.	Length (mm)	Height (mm)	Width (mm)	Weight (kg)	Max pull on flat face(kg)	Max pull on vee'd face (kg)
922	206	63.5	76	3.17	113	104
922 SU (single)	63.5	63.5	51	1.48	113	104

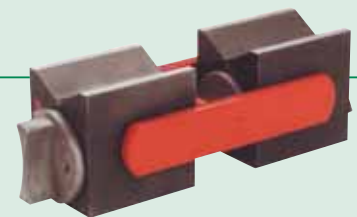

## Magnetic Plate Drag

- This heavy duty plate drag contains powerful permanent ferrite magnets in an aluminium housing
- The E964 Magnetic Plate drag is designed for removal of steel sheets from a stack and safe transportation of sheets to and from machines etc

Product No.	Length (mm)	Height (mm)	Width (mm)	Weight (kg)	pull (kg)
E964	118	98	38	2.8	50



## Recovery Magnet

- This powerful recovery magnet is constructed from a Ferrite magnet sandwiched between two steel plates
- The Eclipse E936 Recovery Magnet is designed for recovery or retrieval applications such as retrieving objects from coolant tanks and vats

Product No.	Width (mm)	Height (mm)	Thickness (mm)	Weight (kg)	Pull (kg)
E936	82.5	101.5	36	1.4	50



## Magnetic Vice Jaws

- The magnet material in the Vice Jaws is neodymium and the surrounding material is polyurethane
- Secures round and irregular workpieces without damage or distortion to any type of workpiece

Product No.	Length (mm)	Height (mm)	Width (mm)	Weight per pair (kg)
EM983-R	103	32	31	0.13



## Magnetic Sheet Floaters

- These magnetic sheet floaters operate by the use of mutual magnetic repulsion to separate sheets in a stack
- Can be used in conjunction with major machine tools and contributes to production efficiencies when fully integrated into the production flow

Product No.	Width (mm)	Height (mm)	Depth (mm)	Mounting hole size	Weight per pair (kg)
E913	73	76	65	M8	1.40
E914	92	102	76	M8	3.10
E915	113	152	89	M10	6.75



## Magnetic Tool Rack

- The toolrack contains 2 x 350mm powerful magnet bars with extruded magnetic rubber lengths housed between two pole pieces
- The EM895-R Magnetic Tool Rack will neatly and securely hold tools in the garage environment and knives in the kitchen

Product No.	Length (mm)	Height (mm)	Width (mm)	Weight (kg)	Pull (kg)
EM895-R	350	45	20	0.55	1



## Telescopic Pick-up Magnet

- Powerful Neodymium Iron Boron magnets are used to ensure maximum pull for a small magnetic area
- Ideal for retrieving ferrous objects that are out of reach

Product No.	Length (mm)	Weight (kg)
EM967-R	147 (retracted)	0.04
	660 (extended)	



## Magnetic Tool Mat

- This handy magnetic tool mat consists of 3 strong Ferrite magnets encapsulated in a tough PVC casing
- Widely used in production areas for keeping tools and parts within easy reach.
- Magnetic both sides

Product No.	Thickness (mm)	Height (mm)	Width (mm)	Weight (kg)	Max pull (kg)
EM981-R	15	150	210	0.36	5



# Magnetic Assemblies

## Ferrite Magnetic Hooks

Product No.	Diameter	Height	Pull (N)
E879	25	34	40
E880	32	34	80
E881	36	34	100

All dimensions are in millimetres



## Samarium Cobalt Deep Pot Magnet

• Maximum temperature 200°C

Product No.	Diameter	Height	Weight (g)	Pull (N)
E750	6	20	4	8
E751	8	20	7	22
E752	10	20	11	40
E753	13	20	19	60
E754	16	20	29	125
E755	20	25	57	230
E756	25	35	128	400
E757	32	40	228	600

All dimensions are in millimetres



## Alnico Deep Pot Magnets

• Maximum temperature 400°C

Product No.	Diameter	Height	Weight (g)	Pull (N)
E730	6	10	2	2
E731	8	12	4	3
E732	10	16	9	5
E733	13	18	17	10
E734	16	20	29	15
E735	20	25	57	35
E736	25	30	110	80
E737	32	35	200	150
E738	40	45	420	200
E739	50	50	720	350

All dimensions are in millimetres



## Samarium Cobalt Shallow Pot Magnets

• Maximum temperature 200°C

Product No.	Diameter	Height	Weight (g)	Pull (N)
E760	6	4.5	1	5
E761	8	4.5	1.5	11
E762	10	4.5	2.5	12
E763	13	4.5	4.5	40
E764	16	4.5	6.5	60
E765	20	6	15	90
E766	25	7	22	150
E767	32	7	40	220

All dimensions are in millimetres



## Ferrite Pot Magnet - Thread Hold

• Maximum temperature 100°C

Product No.	Diameter	Height	Weight (g)	Thread size	Pull (N)
E860	10	4.5	3	M3	4
E861	13	4.5	5	M3	10
E862	16	4.5	6	M3	18
E863	20	6	11	M3	30
E864	25	7	22	M4	40
E865	32	7	32	M4	80
E866	36	7	45	M4	100
E867	40	8	60	M5	125
E868	47	9	90	M4	180
E869	50	10	110	M6	220
E870	57	11	145	M4	280
E871	63	14	240	M8	350
E872	80	18	520	M10	600
E873	90	20	325	M10	700
E874	100	22	940	M14	900
E875	125	26	1700	M14	1300

All dimensions are in millimetres



## Ferrite Shallow Pot Magnet - Fixed Hole

• Maximum temperature 100°C

Product No.	Diameter	Height	Weight (g)	Hole Size	Pull (N)
E876	25	7	16	4.2	36
E877	32	7	27	5.5	72
E878	40	8	53	5.5	90

All dimensions are in millimetres



## Merchandise Display Stands

Three sizes to maximise your sales:



### Large Merchandiser Order Code MDU-1

- Floor mounted / free standing.
- Designed to display all 52 magnet types.
- Product Pack A completely covers this display unit.
- Unit size:
 

Width	770mm
Depth	430mm
Height	1860mm
- Eclipse Magnetics produces over 20,000 different types of magnet. The top 52 most popular magnets are displayed on this merchandiser - a magnet for every application.

### Small Merchandiser Order Code MDU-2

- Free standing counter top unit.
- Designed to display 22 magnet types - suitable to display Product Packs B, C or D.
- Unit size:
 

Width	610mm
Depth	300mm
Height	820mm
- Light weight unit
- Ideal to ensure a high level of interest and impulse buys

### Micro Merchandiser Order Code MDU-3

- Compact free standing counter top unit.
- Designed to display 11 magnet types - suitable to display Product Packs B, C or D or F.
- Unit size:
 

Width	305mm
Depth	300mm
Height	820mm
- Ultra light weight unit

## Product Pack A - All 52 Types

### Order Code: MRP-A



Total Quantity = 52

- Includes 1 off each of the following:

E801-RB	E822-RB	E842-RB	E868-RB
E802-RB	E823-RB	E843-RB	E876-RB
E803-RB	E824-RB	E844-RB	E877-RB
E805-RB	E825-RB	E845-RB	E878-RB
E806-RB	826-RB	E846-RB	E879-RB
E807-RB	827-RB	E860-RB	E880-RB
E808-RB	828-RB	E861-RB	E881-RB
E809-RB	829-RB	E862-RB	N700-RB
E810-RB	830-RB	E863-RB	N701-RB
811-RB	831-RB	E864-RB	N702-RB
812-RB	832-RB	E865-RB	N703-RB
813-RB	833-RB	E866-RB	N704-RB
E821-RB	834-RB	E867-RB	N750-RB

## Product Pack B - Red Painted Range

### Order Code: MRP-B



Total Quantity = 22

- Includes 1 off each of the following:

E801-RB	E824-RB
E802-RB	E825-RB
E803-RB	826-RB
E805-RB	827-RB
E807-RB	828-RB
811-RB	829-RB
812-RB	830-RB
813-RB	831-RB
E821-RB	833-RB
E822-RB	834-RB
E823-RB	E845-RB

# Merchandise Range

## Product Pack C - Chrome & Neodymium Range

**Order Code: MRP-C**



Total Quantity = 22

• Includes 1 off each of the following:

813-RB	E877-RB
E860-RB	E878-RB
E861-RB	E879-RB
E862-RB	E880-RB
E863-RB	E881-RB
E864-RB	N700-RB
E865-RB	N701-RB
E866-RB	N702-RB
E867-RB	N703-RB
E868-RB	N704-RB
E876-RB	N750-RB

## Product Pack D - Assorted Range

**Order Code: MRP-D**



Total Quantity = 22

• Includes 1 off each of the following:

E802-RB	E863-RB
E803-RB	E864-RB
E806-RB	E865-RB
811-RB	E868-RB
813-RB	E879-RB
E824-RB	E880-RB
832-RB	N700-RB
834-RB	N702-RB
E860-RB	N703-RB
E861-RB	N704-RB
E862-RB	N750-RB

## Product Pack F - Assorted Range

**Order Code: MRP-F**



Total Quantity = 33

• Includes 1 off each of the following:

E802-RB	E824-RB	E866-RB
E803-RB	E825-RB	E867-RB
E806-RB	830-RB	E868-RB
E808-RB	832-RB	E879-RB
E809-RB	834-RB	E880-RB
811-RB	E860-RB	E881-RB
812-RB	E861-RB	N700-RB
813-RB	E862-RB	N702-RB
E821-RB	E863-RB	N703-RB
E822-RB	E864-RB	N704-RB
E823-RB	E865-RB	N750-RB

## Magnetic Rods

High Intensity Rare Earth Separator Rods are extremely efficient for removing fine ferrous contamination from free flowing products such as sugar, grain, tea and liquids. These rods are ideal for engineers wishing to design their own magnetic separators.

- 1" Diameter
- Magnetic Performance on Rod Surface 9,000 Gauss
- Supplied with M6 Drilled & Tapped hole on one end
- Supplied Fully Tested & Certified
- Rods are available up to 1000mm in length please contact our sales team for more details

Part Number	Length (mm)
SR100	100
SR150	150
SR200	200
SR250	250
SR300	300
SR350	350
SR400	400
SR450	450
SR500	500



## Magnetic Sampling Probe

High Intensity Magnetic Sampling Probes are ideal for Quality Control personnel to quickly and easily carry out product purity inspections on any power granulate or liquid for ferrous contamination.

- Incorporating quick release mechanism
- 76mm Diameter hand guard
- Magnetic Performance on rod surface 9,000 Gauss

Part Number	Magnetic Length (mm)
MSP100	100
MSP200	200
MSP300	300



## Permanent Magnetic Separators...

**This range of high intensity "Rare Earth" magnetic separators are used extensively throughout the food industry for the effective removal of ferrous contaminants from processed products. All Rods are highly polished and manufactured using 316 Stainless Steel.**

## Magnetic Grids – Square

Magnetic grids are constructed from a number of highly polished magnetic rods, which are held in position at pre-determined centres. The rods emit powerful magnetic flux fields across the gaps between the rods and these reach into the product stream, attracting and securing ferrous contamination as it flows through. Once attracted, the contamination sticks to the surface of the rod and eventually seeks sanctuary on the underside of the rod where it is safe from wash off effects of continuous flow.

- Supplied Fully Tested & Certified
- Two-sided frame design
- Magnetic Performance on rod surface 9,000 Gauss

Part Number	Size (mm)	Rod Centre's (mm)	Number of Rods	Weight (Kgs)
GM1515/HS	150 x 150	60	2	2
GM2020/HS	200 x 200	60	3	3.4
GM2525/HS	250 x 250	55	4	5.2
GM3030/HS	300 x 300	55	5	7.4
GM3535/HS	350 x 350	55	6	10



## Easy Clean Magnetic Grids - Square

Easy Clean Grids can be cleaned in seconds. Simply enable the release mechanism, pull the magnetic cores out of the Stainless Steel cartridge and any attracted contamination will simply fall away

- Four-sided frame design
- Magnetic Performance on rod surface 9,000 Gauss
- Supplied Fully Tested & Certified



Part Number	Size (mm)	Rod Centres (mm)	Number of Rods	Weight (Kgs)
EC1515/HS	150 x 150	60	2	3.4
EC2020/HS	200 x 200	60	3	5
EC2525/HS	250 x 250	55	4	7.2
EC3030/HS	300 x 300	55	5	9.6
EC3535/HS	350 x 350	55	6	12.8

## Magnetic Grids - Circular

Circular Magnetic Grids are easily placed into hoppers, product intake points and at finished goods outlet points. They are installed in seconds and provide guaranteed instant protection. Contamination such as rust, stainless steel scrapings and wear from process machinery are often too small to be detected by a Metal Detector, but are easily removed by these highly efficient Magnetic Grids.

- Magnetic Performance on rod surface 9,000 Gauss
- Supplied Fully Tested & Certified

Part Number	Diameter (mm)	Number of Rods	Weight (Kgs)
CG100/HS	100	2	2
CG150/HS	150	3	3
CG200/HS	200	3	4
CG250/HS	250	4	6
CG300/HS	300	5	10
CG350/HS	350	6	12
CG400/HS	400	7	15
CG450/HS	450	7	18
CG500/HS	500	8	24

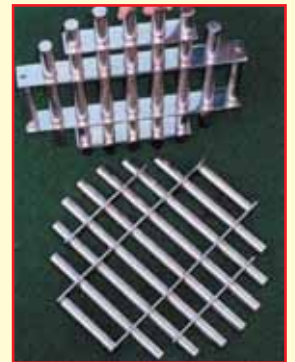

## Magnetic Strips

These units are extremely versatile and can be placed above conveyors, at the side of chute work or even placed on finished product outlet points. High Intensity Rare Earth Neodymium magnets are fully encased within a stainless steel shroud allowing the unit to be utilized in wet applications. Deep fields of magnetic energy are emitted from the front face attracting ferrous contamination as it passes the magnetic face.

- Manufactured using 304 stainless steel
- Units supplied brushed finish
- Complete with threaded holes to rear face for mounting.
- Magnetic performance on Strip surface 5,000 Gauss



Part Number	Size (mm)	Weight (Kgs)
	(length x width x depth)	
SMN100	100 x 100 x 50	2.5
SMN200	200 x 100 x 50	5
SMN300	300 x 100 x 50	7.5
SMN400	400 x 100 x 50	10
SMN500	500 x 100 x 50	12.5
SMN600	600 x 100 x 50	15
SMN700	700 x 100 x 50	17.5
SMN800	800 x 100 x 50	20
SMN900	900 x 100 x 50	22.5
SMN1000	1000 x 100 x 50	25



**ECLIPSE**  
**MAGNETICS**

### Product Support

In the event of queries, please contact the following for expert assistance.

Eclipse Magnetics Ltd  
Atlas Way, Atlas North, Sheffield, S4 7QQ, England  
Tel: ++44 (0)114 225 0600, Fax: ++44 (0)114 225 0610  
E-mail: sales@eclipse-magnetics.co.uk  
Website: www.eclipse-magnetics.co.uk

#### Contact:

Mr Graham Thorpe  
Technical Sales Manager - Handling Systems  
& Workholding

Mr Peter Rowsell  
Distribution Sales Manager - Export

Mr Martyn Cotterill  
Distribution Sales Manager - UK  
Separation Engineer

Mr Steve McAllorum  
Technical Sales Manager - Separation

Mr Tim Hollingsworth  
Industrial Sales Manager - Magnet Materials

Mr Mark Ward  
VP Sales USA  
mward@eclipsemagnetics.com



EM APC UK/3



*Call for more information...*

TEL **++44 (0)114 225 0600**

FAX **++44 (0)114 225 0610**

**Eclipse Magnetics Ltd**  
Atlas Way, Atlas North, Sheffield, S4 7QQ, England

E-mail: [sales@eclipse-magnetics.co.uk](mailto:sales@eclipse-magnetics.co.uk)  
Website: [www.eclipse-magnetics.co.uk](http://www.eclipse-magnetics.co.uk)

A Spear & Jackson PLC Group Company